

NOTE

- 1. Material: Stainless steel
- 2. Thickness: 0.08mm
- 3. Electroplate:
 - Au >1u" on contact area
 - Gold Flash on Solder area
 - Nickel Underplating over All

AMTEK 糧德
2019.05.14
Released DCC

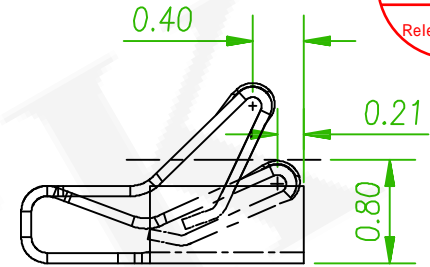
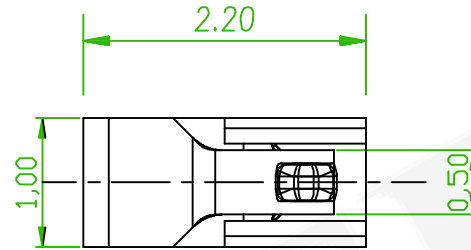
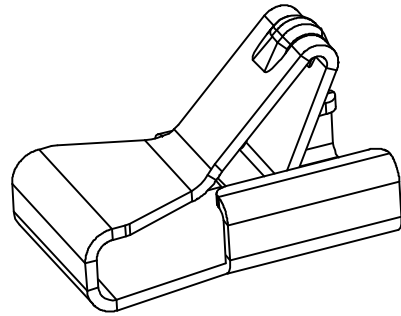

State at
working height 0.80mm

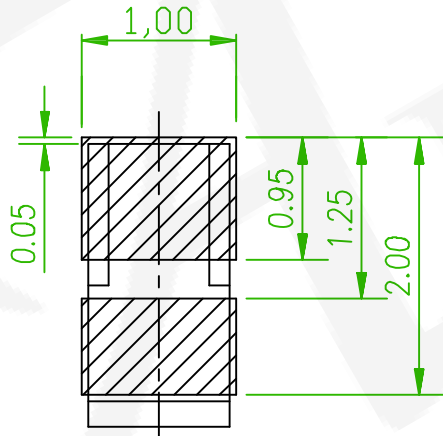

RECOMMENDED PCB LAYOUT
TOLERANCE ±0.05MM
(FOR REFERENCE ONLY)

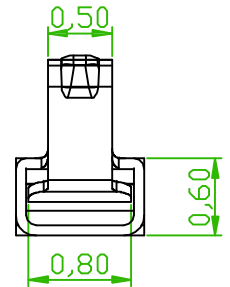
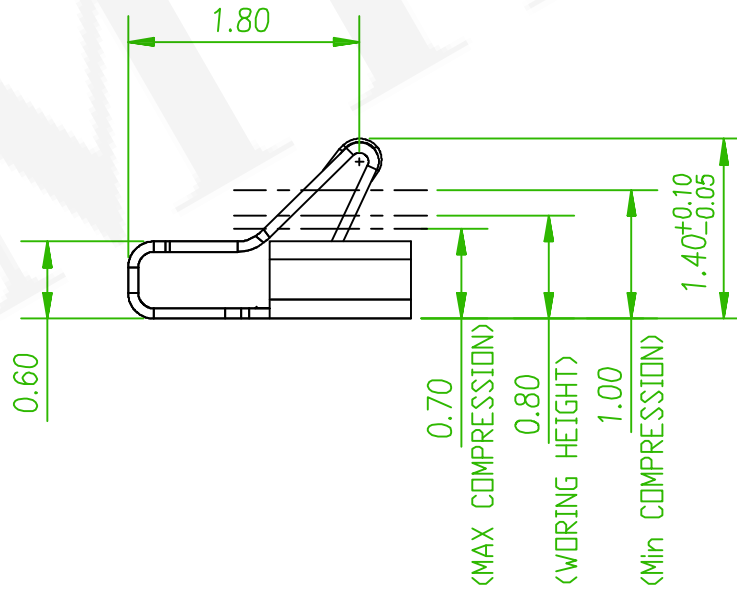

REV.	ECN NO. OR DESCRIPTION	REVISED	DATE

 糧德精密有限公司 Amtek Technology Co., Ltd. TEL: 886-2-2260-6878 FAX: 886-2-2260-8030	品名 TITLE	EMI SPRING			頁數 Page	1/1
	品號 PART NO.	3SQT-NN14NN-NNNNG			繪圖 DRAWN	Nick 2019/05/13
	圖號 DRAWING NO.	GW271-NI141	版本 REV.	A	核對 CHECKED	Josh 2019/05/13
	客戶品號 CUSTOMER P/N		比例 SCALE	None	承認 APPROVED	Josh 2019/05/13
	公差 TOLERANCE	±0.20	單位 UNIT	mm	THIRD ANGLE PROJECTION	