

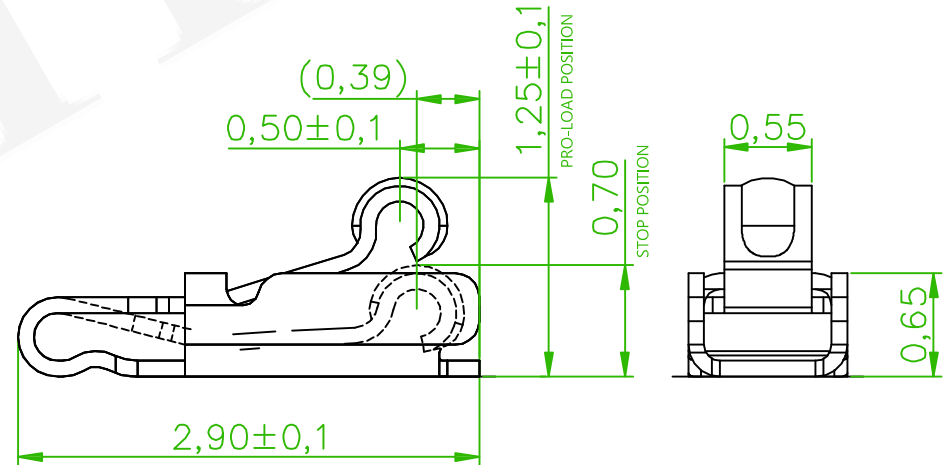

**NOTE**

1. Material: Copper Alloy
2. Thickness: 0.10mm
3. Electroplate:
  - Au 1~3u" on contact area
  - Gold Flash on Solder area
  - Nickel Underplating over All
4. Operating Temperature: -20°C to +85°C
5. Impedance: 30 Ω
6. Contact Resistance: Normal Compression <30mΩ
7. Durability: 1000Cycles
8. Normal Force: Working H0.7mm, 30g min
9. Rated Current: 1.5A
10. Rated Voltage: 5V

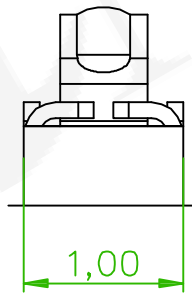
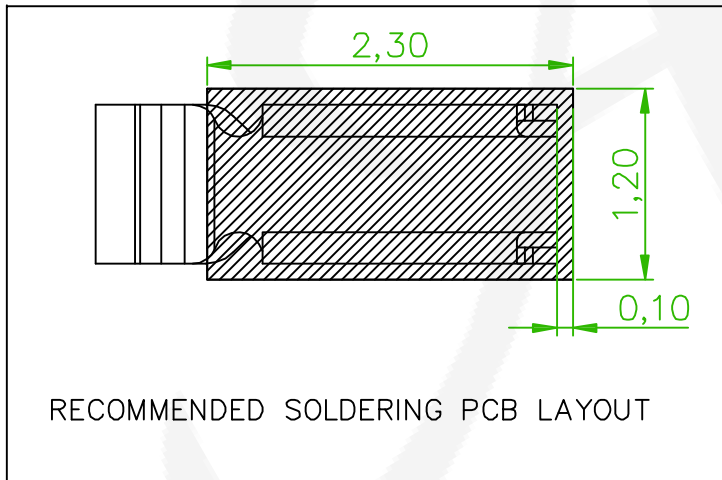
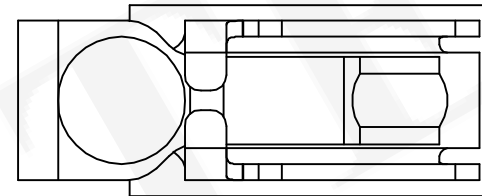
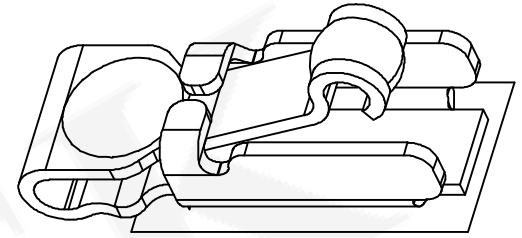

REV.	ECN NO. OR DESCRIPTION	REVISED	DATE

 糧德精密有限公司 Amtek Technology Co., Ltd. TEL: 886-2-2260-6878 FAX: 886-2-2260-8030	品名 TITLE	EMI SPRING				頁數 Page	1/1
	品號 PART NO.	3SQT-NN12NN-NNNNG			繪圖 DRAWN	Nick 2019/05/13	
	圖號 DRAWING NO.	GW271-NI140	版本 REV.	A	核對 CHECKED	Josh 2019/05/13	
	客戶品號 CUSTOMER P/N		比例 SCALE	None	承認 APPROVED	Josh 2019/05/13	
	公差 TOLERANCE	±0.20	單位 UNIT	mm	THIRD ANGLE PROJECTION	