

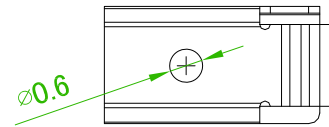

NOTE

Material: BeCu
 Thickness: 0.12mm
 Plated: Gold Flash on Contact Area
 Gold Flash on Solder Area
 Nickel Underplating over All
 Height of Application: 2.70 to 3.80mm(Single Actuation)
 2.75 to 3.80mm(Repeated Actuation)

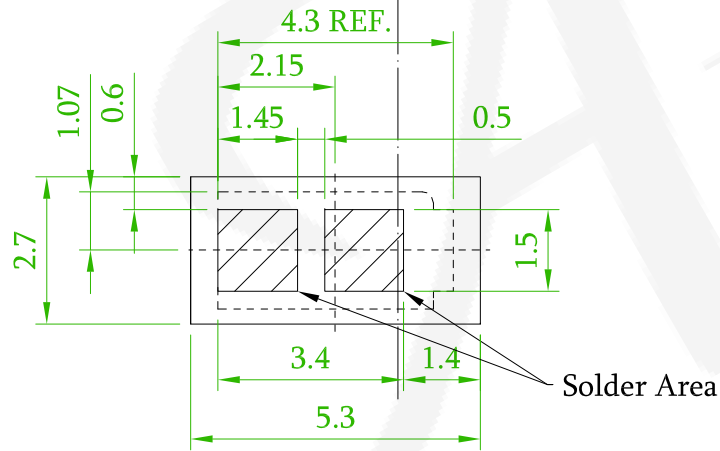
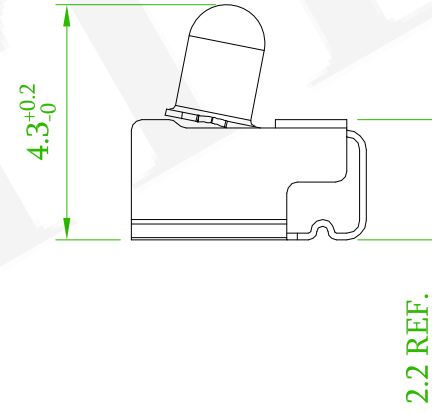
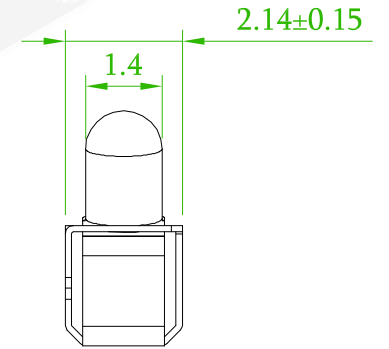
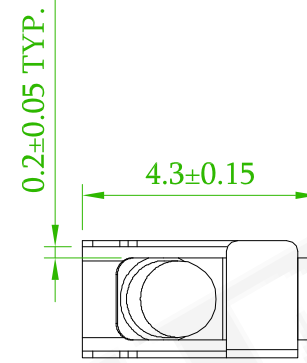
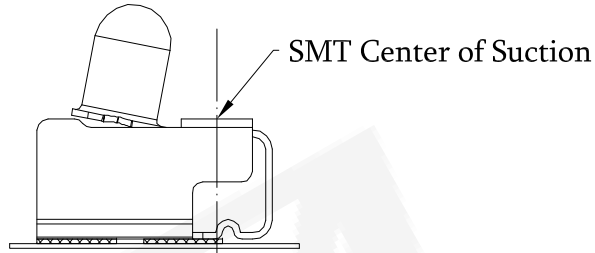
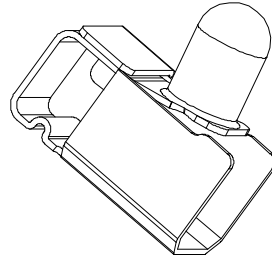

Recommended PCB Layout
 (PCB TOLERANCE ±0.1)

REV.	ECN NO. OR DESCRIPTION	REVISED	DATE
------	------------------------	---------	------

 糧德精密有限公司 Amtek Technology Co., Ltd. TEL: 886-2-2260-6878 FAX: 886-2-2260-8030	品名 TITLE	EMI SPRING			頁數 Page	1/1
	品號 PART NO.	3SQQ-NN43NN-NNA1G			繪圖 DRAWN	Gary 2018/05/29
	圖號 DRAWING NO.	GW271-GB186	版本 REV.	A	核對 CHECKED	Josh 2018/05/29
	客戶品號 CUSTOMER P/N		比例 SCALE	None	承認 APPROVED	Jason 2018/05/29
	公差 TOLERANCE	±0.10	單位 UNIT	mm	THIRD ANGLE PROJECTION	