

**NOTE**

- 1. Material: Be-Cu
- 2. Thickness: 0.08mm
- 3. Electroplate:
  - Gold Flash on contact area
  - Gold Flash on Solder area
  - Nickel Underplating over All
- 4. Height of Application:
  - 0.55~1.55mm(Single actuation)
  - 0.60~1.55mm(Repeated actuation)

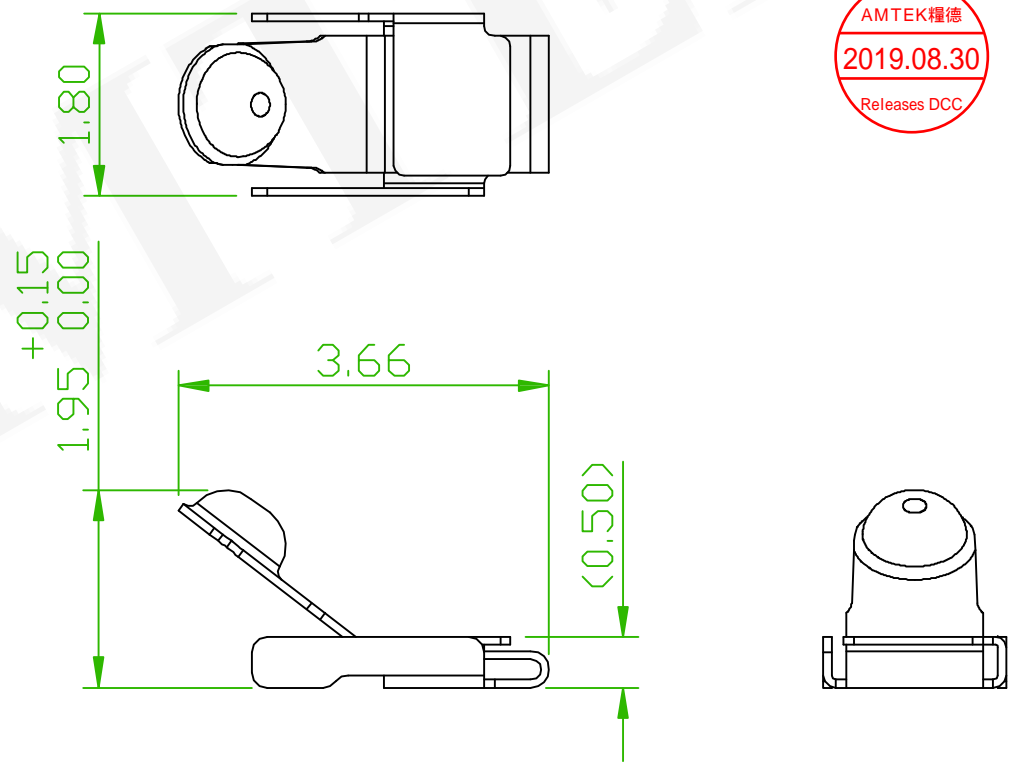
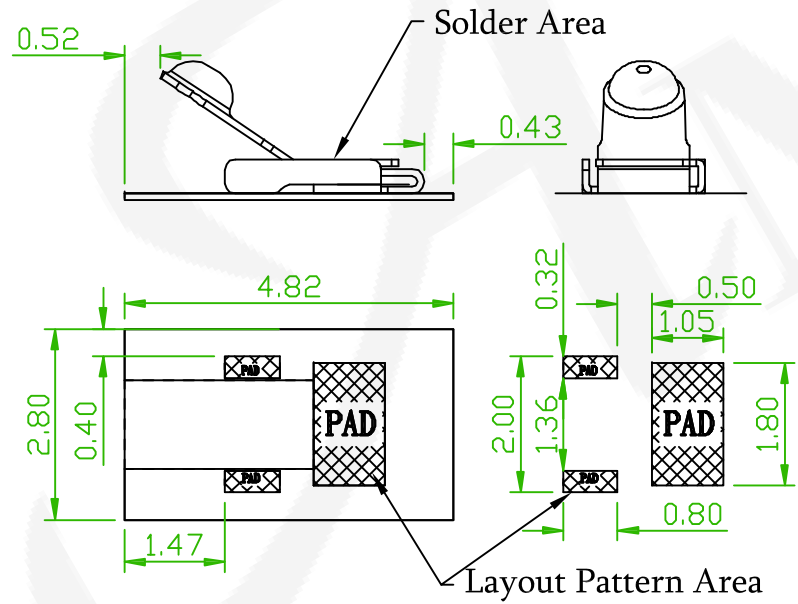
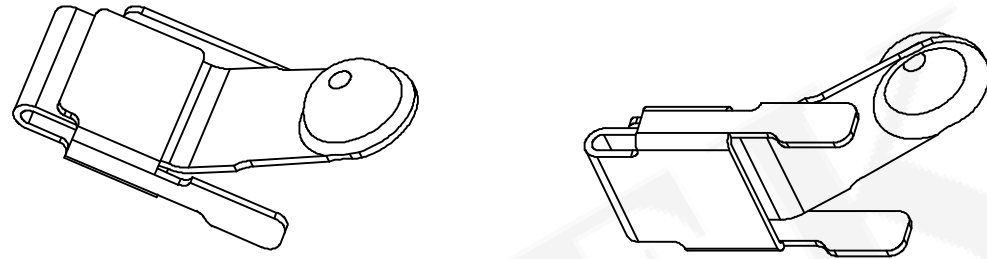

Recommended PCB Layout  
(PCB TOLERANCE ±0.1)

REV.	ECN NO. OR DESCRIPTION	REVISED	DATE

<p>耀德精密有限公司 Amtek Technology Co., Ltd. TEL: 886-2-2260-6878 FAX: 886-2-2260-8030</p>	品名 TITLE	EMI SPRING			頁數 Page	1/1
	品號 PART NO.	3SQQ-NN19NN-NNNG			繪圖 DRAWN	Nick 2019/08/30
	圖號 DRAWING NO.	GW271-NI338	版本 REV.	A	核對 CHECKED	Josh 2019/08/30
	客戶品號 CUSTOMER P/N		比例 SCALE	None	承認 APPROVED	Josh 2019/08/30
	公差 TOLERANCE	±0.20	單位 UNIT	mm	THIRD ANGLE PROJECTION	