

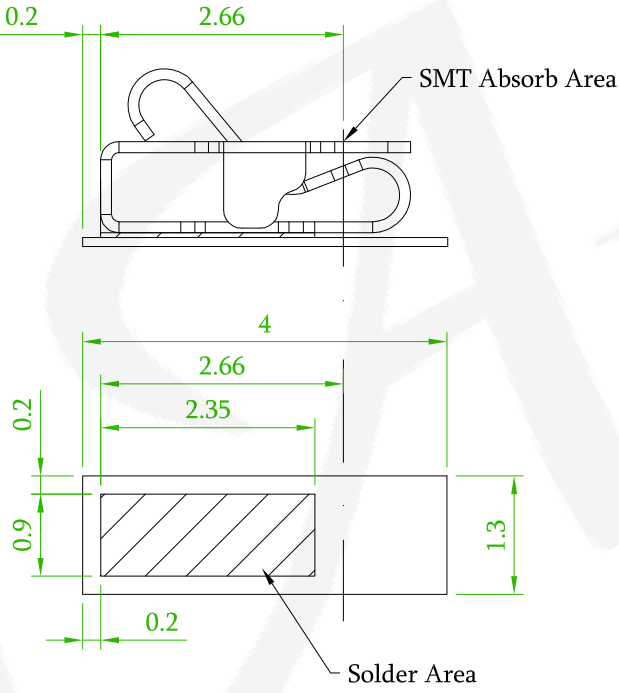

NOTE

Material: Be-Cu
 Thickness: 0.12mm
 Plated: Au 1u" on Contact Area Min.
 Au 1u" on Solder Area Min.
 Nickel Underplating over All
 Height of Application: 1.0 to 1.5mm (Single Actuation)
 1.2 to 1.5mm (Repeated Actuation)

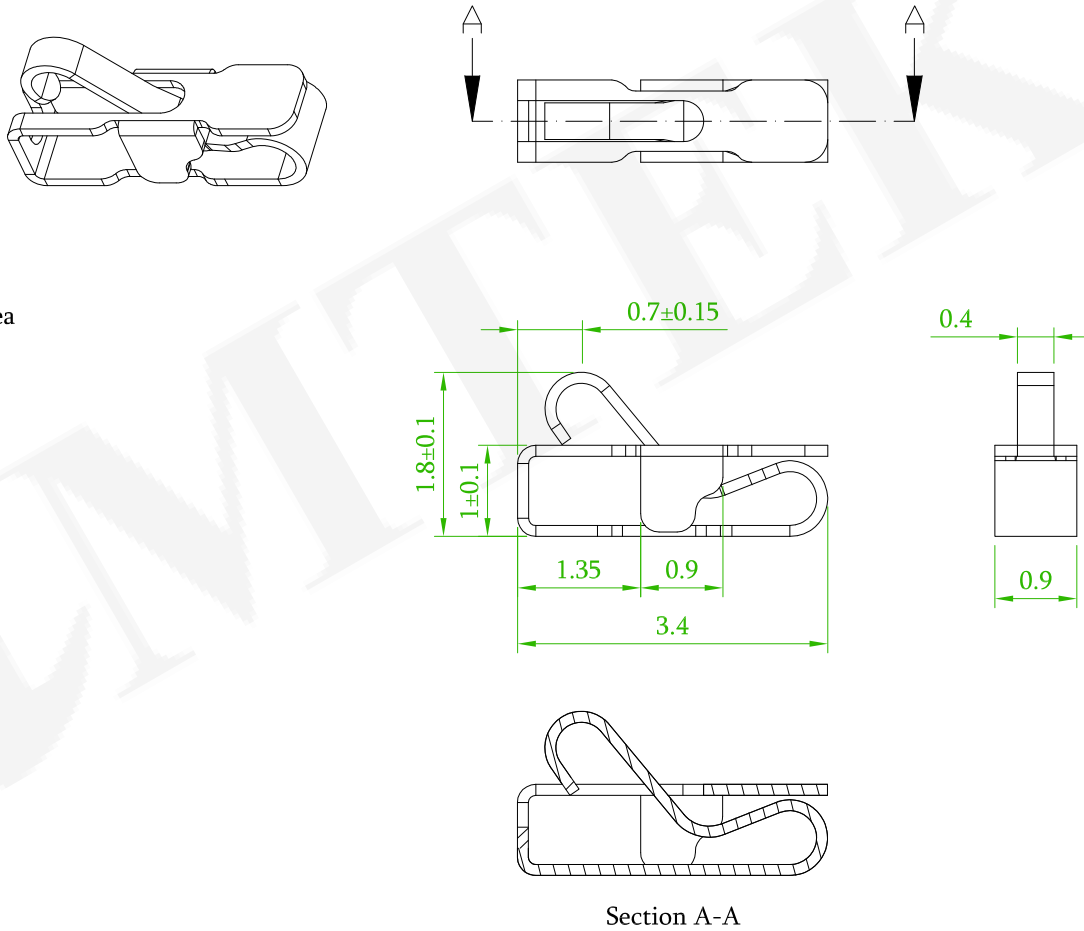

Recommended PCB Layout
 (PCB TOLERANCE ±0.1)

 耀德精密有限公司 Amtek Technology Co., Ltd. TEL: 886-2-2260-6878 FAX: 886-2-2260-8030	品名 TITLE	EMI SPRING				頁數 Page	1/1
	品號 PART NO.	3SQP-NN18NN-A1Q1G			繪圖 DRAWN	Gary 2018/05/03	
	圖號 DRAWING NO.	GW271-GB109	版本 REV.	A	核對 CHECKED	Josh 2018/05/03	
	客戶品號 CUSTOMER P/N		比例 SCALE	None	承認 APPROVED	Jason 2018/05/03	
	公差 TOLERANCE	±0.20	單位 UNIT	mm	THIRD ANGLE PROJECTION		

REV.	ECN NO. OR DESCRIPTION	REVISED	DATE