

CONNECTORS MANUFACTURER



Centronic Right Angle Type

SPECIFICATION

Current Rate:1 AMP
 Insulation Resistance:1000MΩ Min.
 Contact Resistance:30mΩ Max.
 Dielectric Voltage:500V AC for one minute
 Operation Temperature:-55°C to +105°C

MATERIAL

Insulator:Polyester,UL 94V-0
 ◎Standard:PBT
 Contact Pin:Copper Alloy

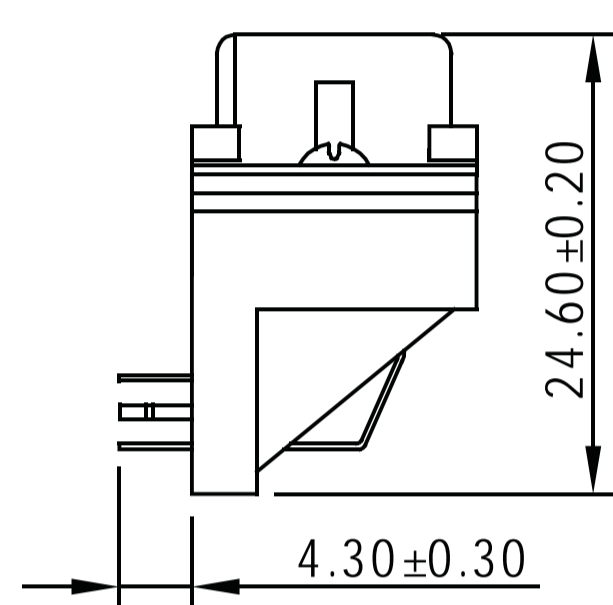
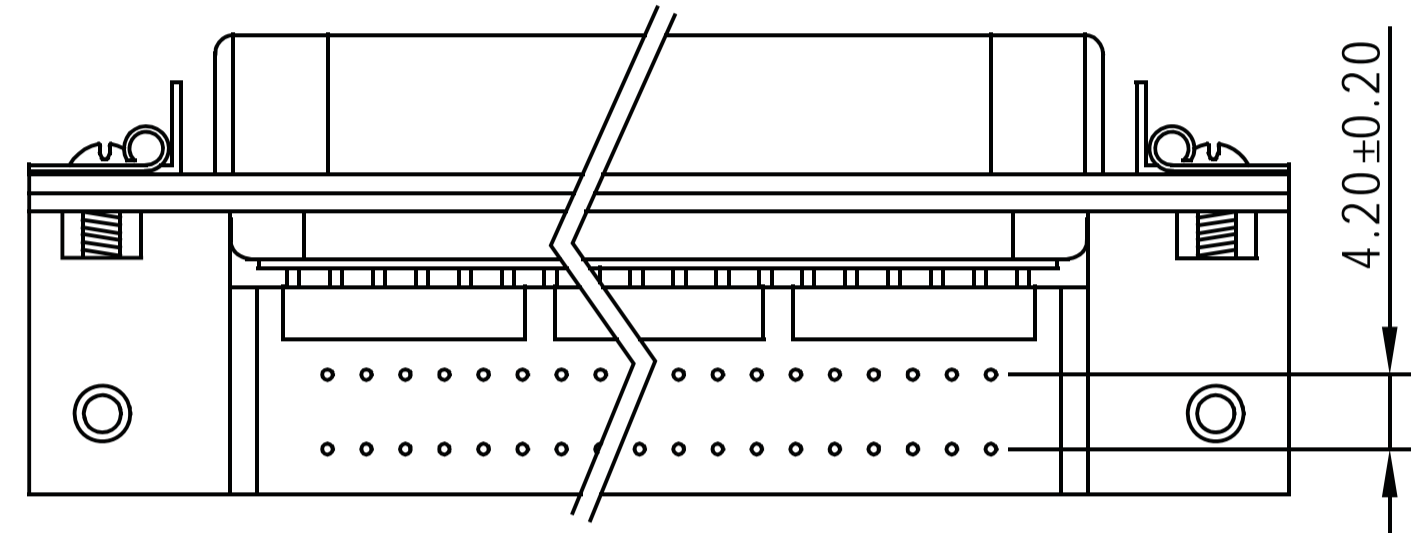
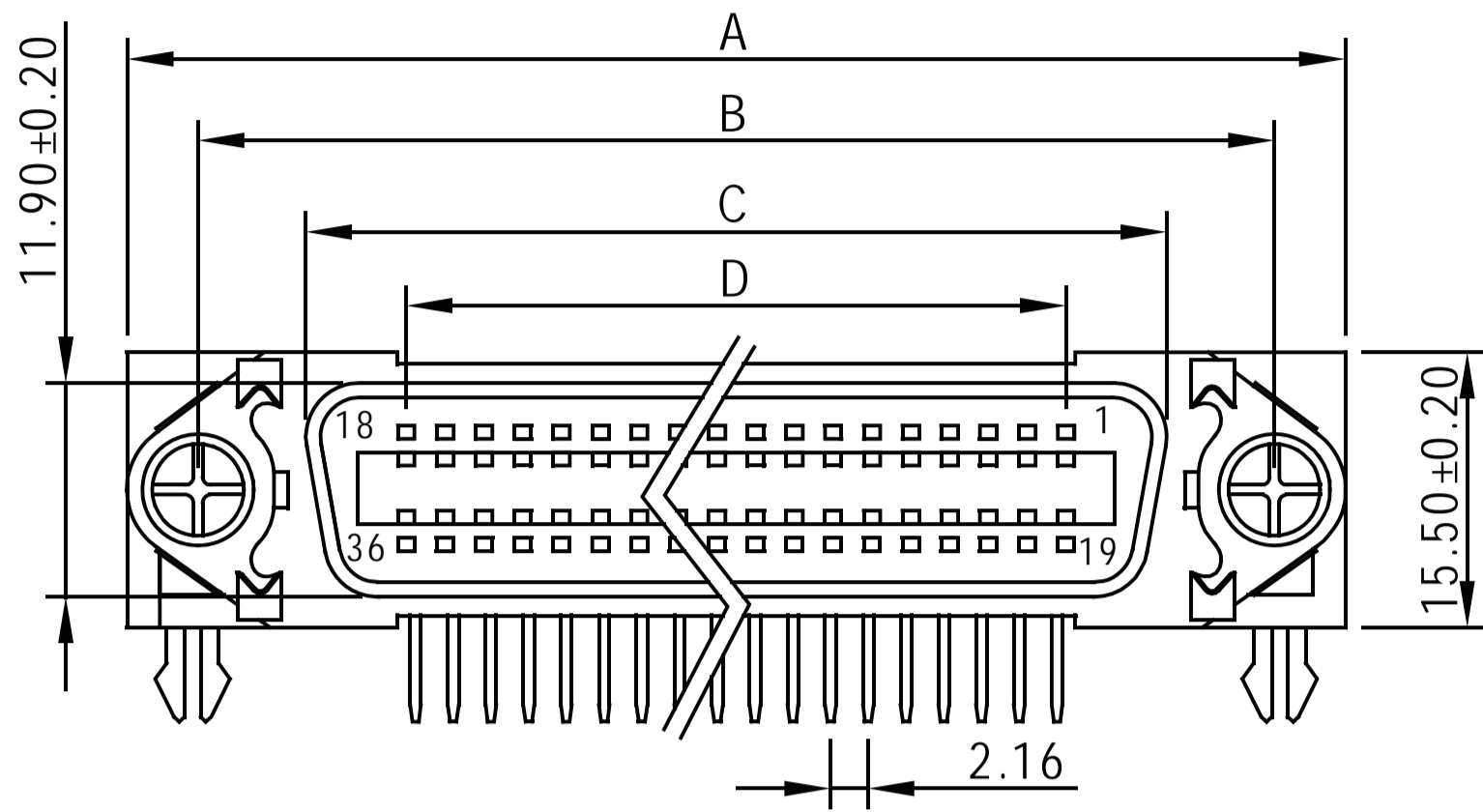
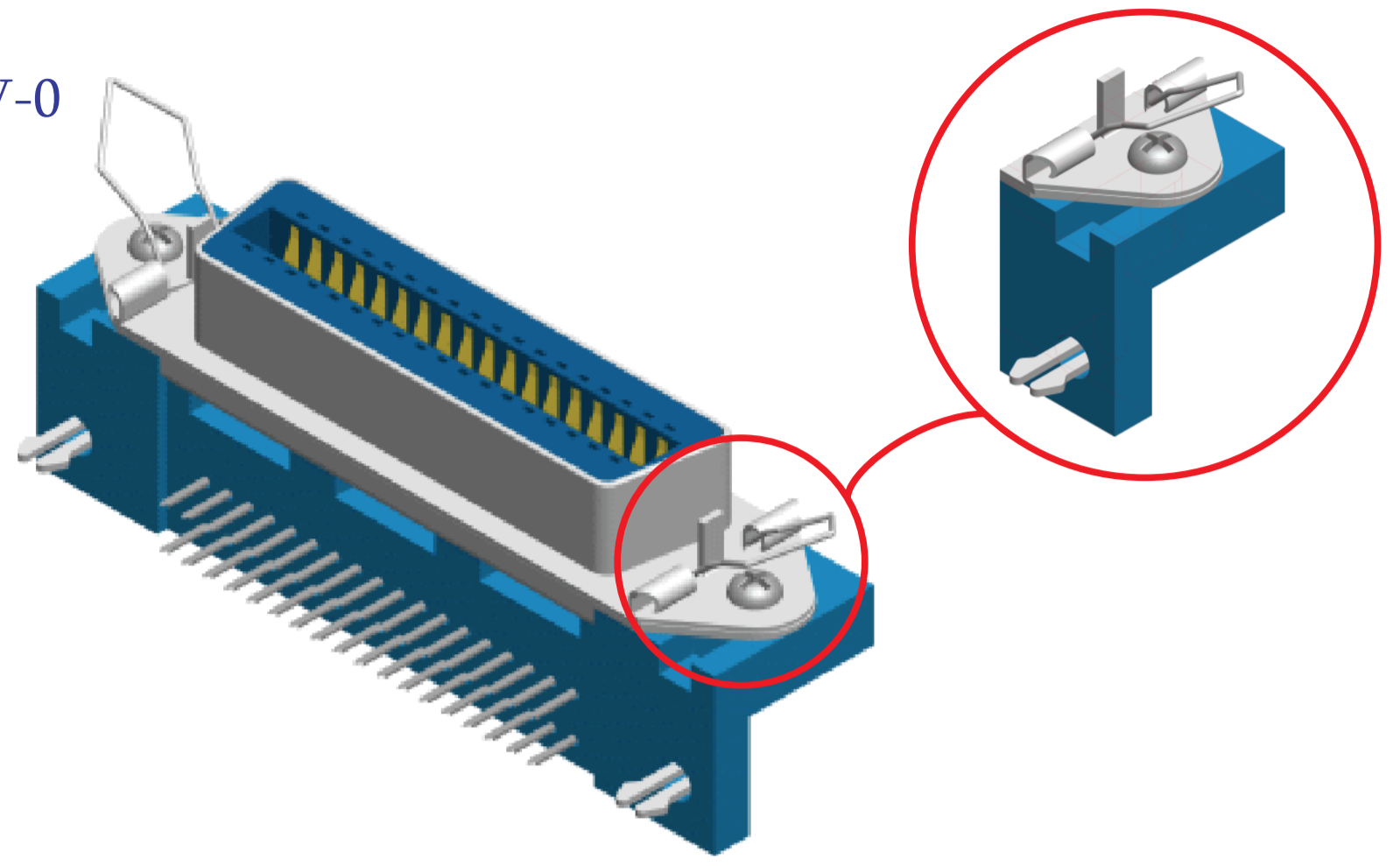

Part No.	A±0.20	B±0.20	C±0.20	D±0.20
CENRA-F14	44.05	35.99	25.20	12.96
CENRA-F24	54.95	46.85	35.65	23.76
CENRA-F36	67.69	59.74	48.90	36.72
CENRA-F50	82.85	74.85	64.10	51.84

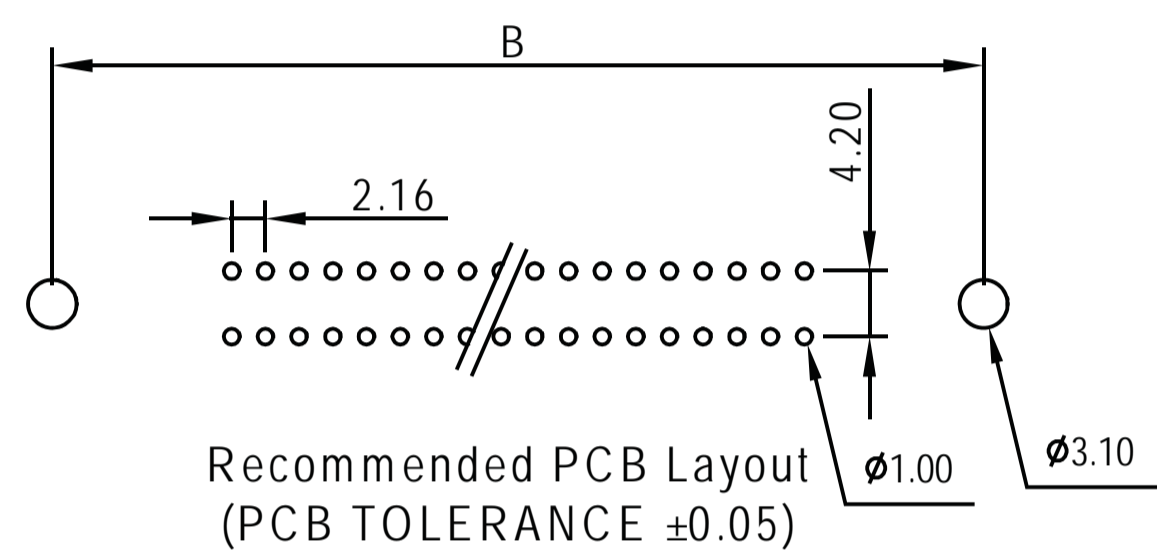

Order Information

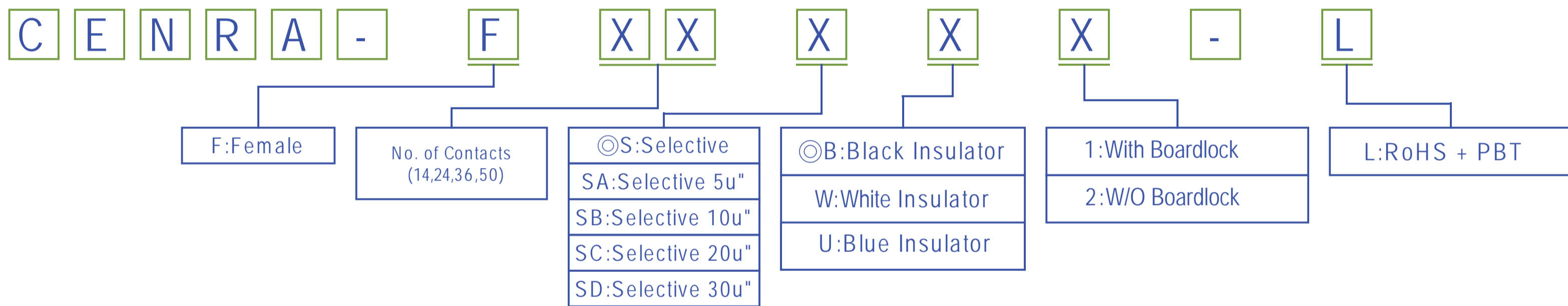

Centronic Right Angle Type

SPECIFICATION

Current Rate:1 AMP
 Insulation Resistance:1000MΩ Min.
 Contact Resistance:30mΩ Max.
 Dielectric Voltage:500V AC for one minute
 Operation Temperature:-55°C to +105°C

MATERIAL

Insulator:Polyester,UL 94V-0
 ◎Standard:PBT
 Contact Pin:Copper Alloy

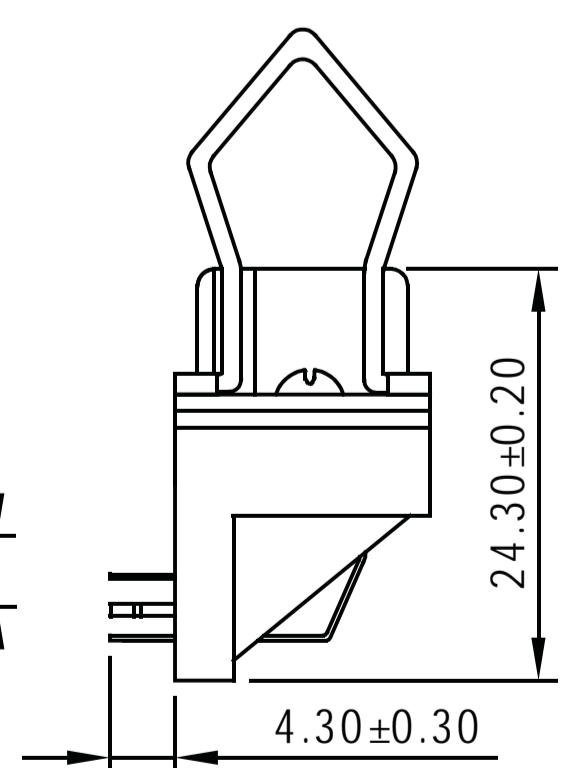
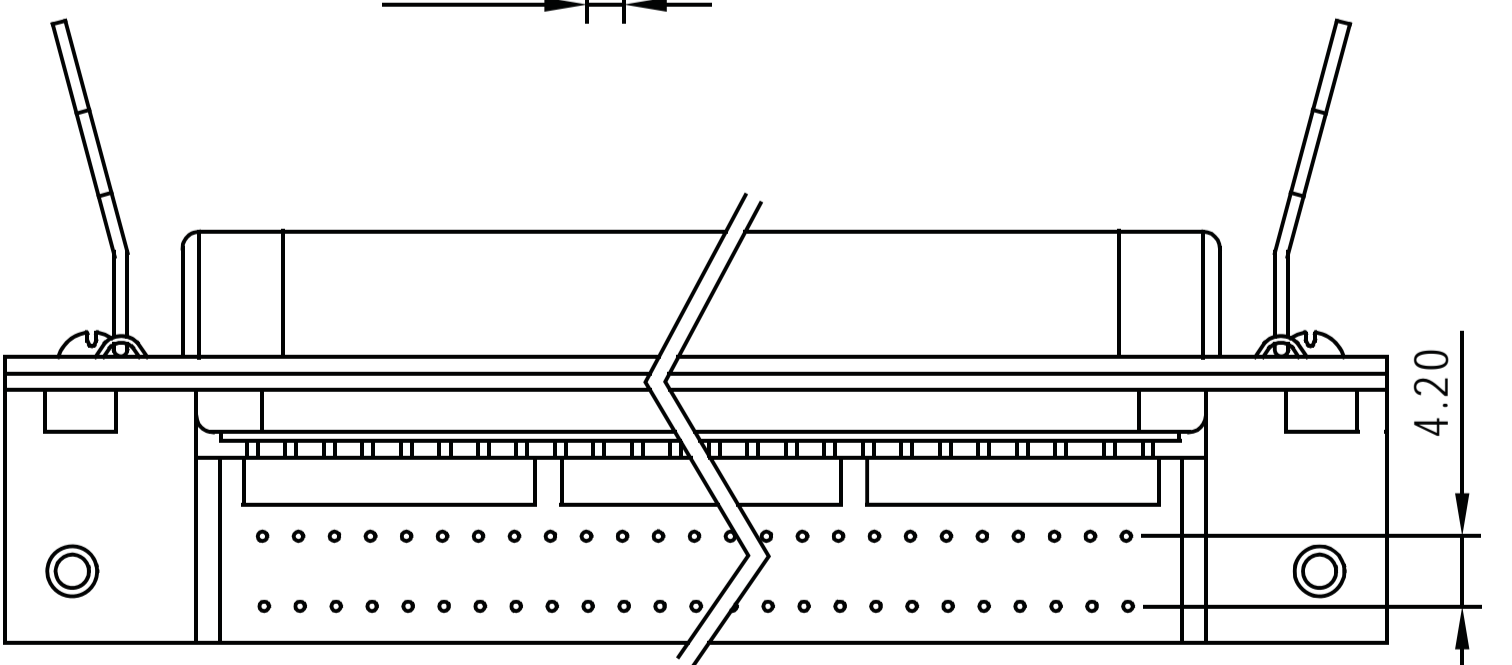
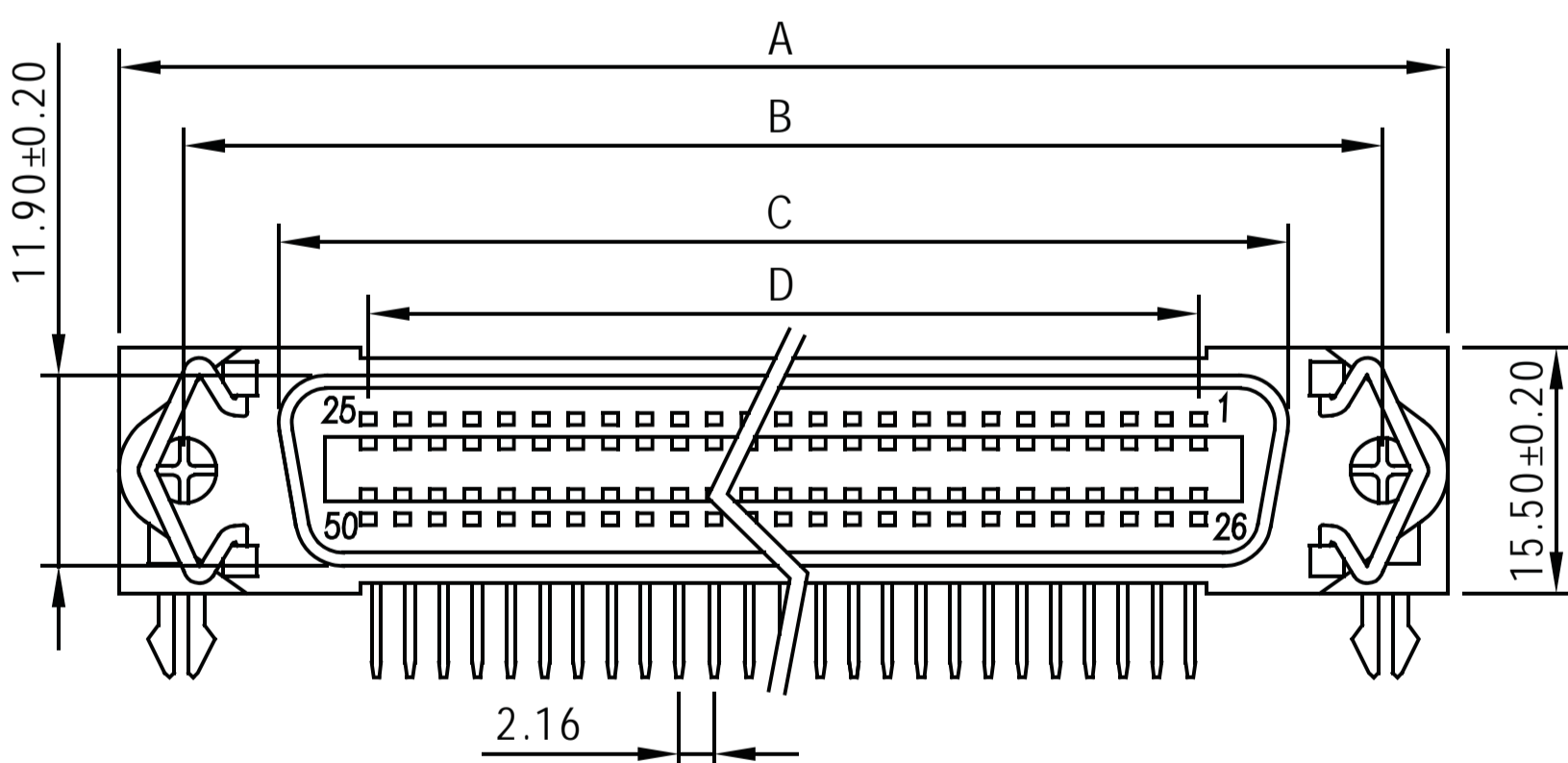
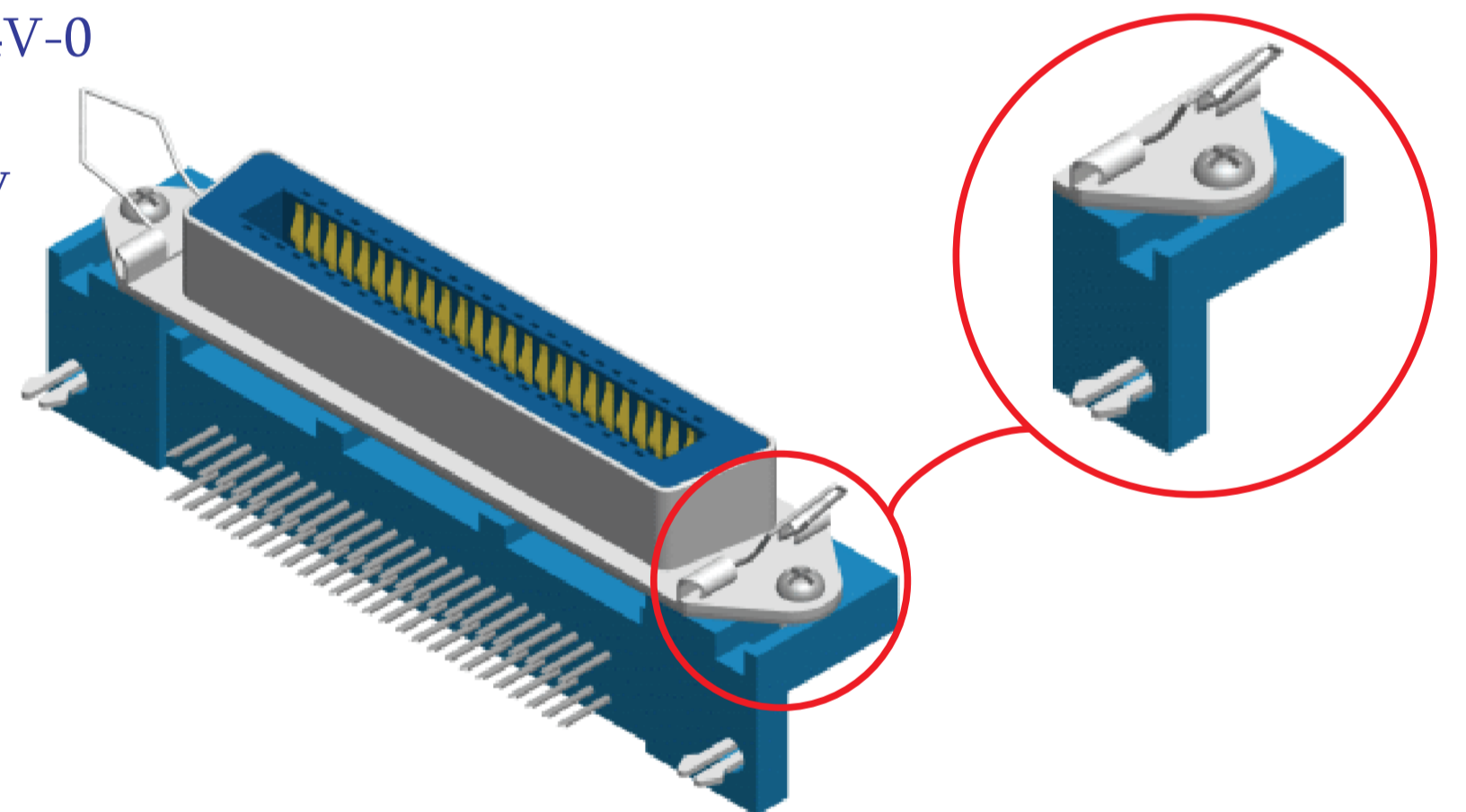

Part No.	A±0.20	B±0.20	C±0.20	D±0.20
CENR-F14	44.05	35.99	25.20	12.96
CENR-F24	54.95	46.85	35.65	23.76
CENR-F36	67.69	59.74	48.90	36.72
CENR-F50	82.85	74.85	64.10	51.84

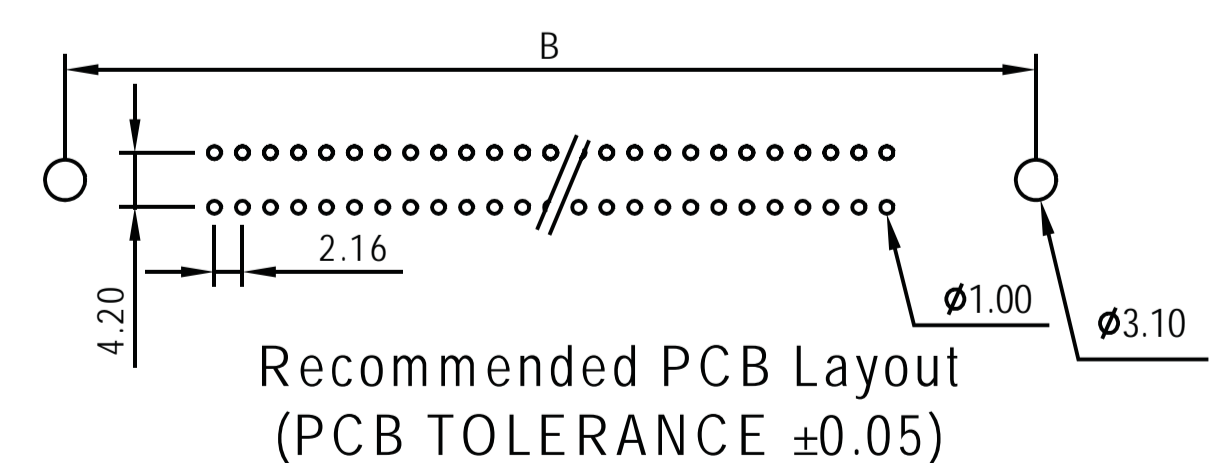

Order Information

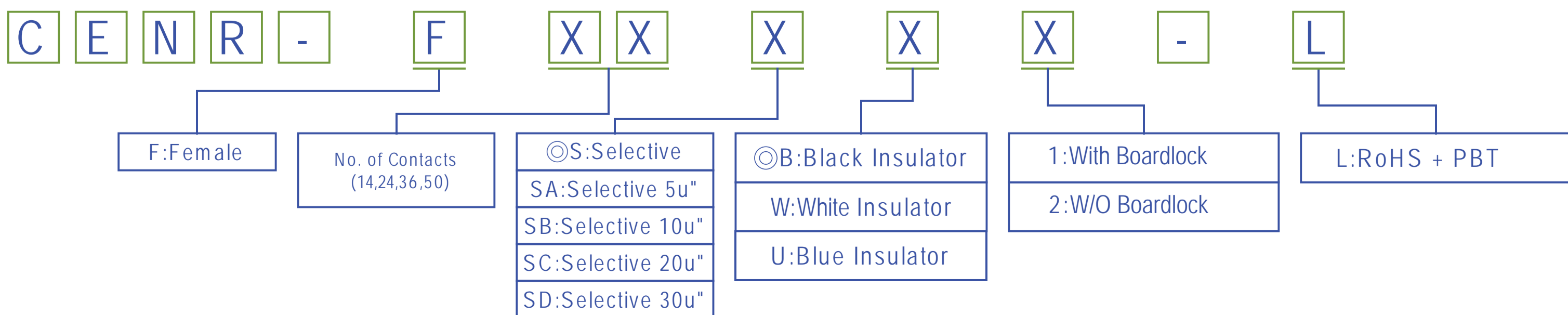

Centronic Conn. Series



RoHS

AMTEK COMMUNICATIONS MANUFACTURE